

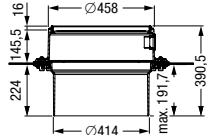



Accessories

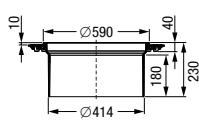

Pumpfix F, Staufix FKA, Staufix SWA and Controlfix

Extension sections

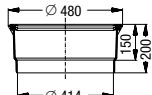
				Art. no.
with centre flange	<p>Compatibility: For installation in a concrete floor <i>Pumpfix F, Staufix FKA, Staufix SWA</i> and <i>Controlfix</i></p> <p>Additional function: For installation in water-proof concrete</p> <p>Inclusive: Temporary construction debris cover, fully assembled, gasket set (counter flange made of polymer, screwed, elastomer sealing sheet made of NK/SBR Ø 800 mm)</p> <p>Extension: Max. 360 mm</p>			83 075
with flange and counter flange	<p>Compatibility: For installation in a concrete floor <i>Pumpfix F, Staufix FKA, Staufix SWA</i> and <i>Controlfix</i></p> <p>Additional function: For connection to an on-site sealing sheet</p> <p>Inclusive: Screws</p> <p>Extension: Max. 140 mm (In case of deeper installation ensure maintenance capability!)</p>			83 073
with gasket	<p>Compatibility: For installation in a concrete floor <i>Pumpfix F, Staufix FKA, Staufix SWA</i> and <i>Controlfix</i></p> <p>Extension: Max. 180 mm (In case of deeper installation ensure maintenance capability!)</p>			83 070

Cable extensions

for extension from 15 m or 25 m (cable length delivered: 5 m)

	for backwater pumping station <i>Pumpfix F</i>	for motorized backwater valve <i>Staufix FKA</i> and <i>Staufix FKA Standard</i> (up to 2015)		Art. no.
Cable extension for motor (10 m)	<p>Extension to 15 m: 1×80 890</p> <p>Extension to 25 m: 2×80 890</p>	<p>Extension to 15 m: 1×80 890</p> <p>Extension to 25 m: 2×80 890</p>		80 890
Cable extension for probe (10 m)	<p>Extension to 15 m: 2×80 889</p> <p>Extension to 25 m: 4×80 889</p>	<p>Extension to 15 m: 1×80 889</p> <p>Extension to 25 m: 2×80 889</p>		80 889
Cable extension for pump (10 m)	<p>Extension to 15 m: 1×80 891</p> <p>Extension to 25 m: 2×80 891</p>			80 891

Cover plates

			Cover	Art. no.
surface water tight	<p>Compatibility: For installation in a concrete floor <i>Pumpfix F, Staufix FKA, Staufix SWA</i> and <i>Controlfix</i></p> <p>Inclusive: Gasket</p> <p>Version recessed for on-site tiling, grey: For tile thicknesses of 18 mm (Ventilation always required when in use!)</p>			<p>tileable 830 052</p> <p>black 830 050</p>

Spigot and Socket

			Outer diameter Ø (mm)	Art. no.
Spigot	<p>Compatibility: For backwater valves <i>Pumpfix F, Staufix FKA, Staufix SWA</i> and <i>Controlfix</i></p> <p>Function: Removable inlets / outlets</p>		<p>Ø 110 83 081</p> <p>Ø 125 83 082</p> <p>Ø 160 83 083</p> <p>Ø 200* 83 084</p>	
Socket	<p>Compatibility: For backwater valves <i>Pumpfix F, Staufix FKA, Staufix SWA</i> and <i>Controlfix</i></p> <p>Function: Removable inlets / outlets</p>		<p>Ø 110 83 085</p> <p>Ø 125 83 086</p> <p>Ø 160 83 087</p> <p>Ø 200* 83 088</p>	

* In-/Outlet Ø 200, hydraulics corresponds to Ø 160