

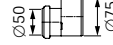



## Accessories

Inlet adaptor		Outer diameter Ø (mm)	Drill size in mm	Art. no.		
<b>with gasket and threaded ring</b>	<b>Compatibility:</b> Ø 50 / Ø 75 / Ø 110: <i>Aqualift S Compact</i> Ø 50 / Ø 75: <i>Minilift S</i> (280 570X, 280 570S, 280 570XC and 280 570SC) <b>Inclusive:</b> Flat seal			Ø 50	60	39 005
				Ø 75	92	39 007
				Ø 110	121	39 100

Transition sections		Outer diameter Ø (mm)	Art. no.		
<b>Transition section</b>	<b>Compatibility:</b> For installation in a concrete floor <i>Aqualift F Compact</i> , <i>Aqualift S Compact</i> and <i>Minilift S</i> (280 570X, 280 570S, 280 570XC and 280 570SC) <b>Inclusive:</b> Sealing ring Ø 50			Ø 50/75	27 126
	<b>Compatibility:</b> For installation in a concrete floor <i>Aqualift F Compact</i> , <i>Aqualift S Compact</i> and <i>Minilift S</i> (280 570X, 280 570S, 280 570XC and 280 570SC) <b>Inclusive:</b> Ø 110 socket / Ø 75 spigot for use as connection piece, gasket			Ø 75/110	27 602

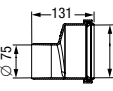
Hole saw		Outer pipe diameter in mm	Drill size in mm	Art. no.		
<b>Hole saw set</b>	<b>Compatibility:</b> Ø 50 - Ø 200: <i>Aqualift F Mono / Duo</i> , <i>Aqualift F XL</i> Ø 50 - Ø 160: <i>Aqualift S 100 / Aqualift S 200</i> Ø 50 - Ø 110: <i>Aqualift F Basic</i> , <i>Aqualift F Compact</i> , <i>Aqualift S Compact</i> Ø 50 / Ø 75: <i>Minilift S</i> (280 570X, 280 570S, 280 570XC and 280 570SC) <b>Inclusive:</b> Saw blade holder			Ø 50	60	500 101
				Ø 75	92	
				Ø 110	121	
				Ø 110	121	500 100
				Ø 125	133	
				Ø 160	168	
				Ø 200 <sup>1)</sup>	200	500 102

1) use a power drill with at least 1000 watts

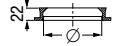
Sealing		Nominal pipe diameter in mm	Outer pipe diameter in mm	Art. no.		
<b>Pipe sealing gasket</b>	<b>Compatibility:</b> DN 50 - DN 200: <i>Aqualift F Mono / Duo</i> , <i>Aqualift F XL</i> DN 50 - DN 150: <i>Aqualift S 100 / Aqualift S 200</i> DN 50 - DN 100: <i>Aqualift F Basic</i> , <i>Aqualift F Compact</i> , <i>Aqualift S Compact</i> DN 50 / DN 70: <i>Minilift S</i> (280 570X, 280 570S, 280 570XC and 280 570SC) <b>Drill size:</b> Ø 50: 60 mm Ø 75: 92 mm Ø 110: 121 mm Ø 125: 133 mm Ø 160: 168 mm Ø 200: 210 mm			DN 50	Ø 50	850 114
				DN 70	Ø 75	850 116
				DN 100	Ø 110	850 117
				DN 125	Ø 125	850 118
				DN 150	Ø 160	850 119
				DN 200	Ø 200	850 123