

Pumping system *Aqualift F XL*

Wet installation, for installation in on-site collection tank



Version contains:

- Pump base, backwater flaps and gate closure valves
- Hydrostatic level sensor
- KESSEL Comfort 400 V control unit
- PE pressure pipe with \varnothing 63 mm (DN 50) and \varnothing 90 mm (DN 80)

Pumping capacity: max. ... m³/h

Voltage: 400 V ~ 50 Hz

Cable length: 10 m

Note: *Aqualift F XL* should be installed in a chamber with a minimum diameter of 1.000 mm



Mono version with one pump

Pump	Art. no.
STZ 1300	STZ1300-M*
STZ 2500	STZ2500-M*
STZ 3700	STZ3700-M*
GTF 1400	GTF1400-M*
GTF 1600	GTF1600-M*
GTF 2600	GTF2600-M*
GTF 4000	GTF4000-M*
GTK 1300	GTK1300-M*
GTK 2600	GTK2600-M*
GTK 3700	GTK3700-M*

Pumping system *Aqualift F XL*:

- with pumps *STZ*
- for wastewater with or without sewage
- Pump(s) with high performance macerating system for operational reliability
- Mono or Duo version
- ATEX Certification

Pumping system *Aqualift F XL*:

- with pumps *GTF*
- for wastewater with or without sewage (check your local ATEX regulations)
- with multi-vane impeller
- Mono or Duo version

Pumping system *Aqualift F XL*:

- with pumps *GTK*
- for wastewater with or without sewage (check your local ATEX regulations)
- single-channel impellered pumps - high performance, ultra-low energy usage
- Mono or Duo version

On request:

- Vertical pressure outlet
- Variable pressure pipe height / lengths
- Custom pressure pipe sizes

➤ **Accessories:** Pump removal chain see page 171

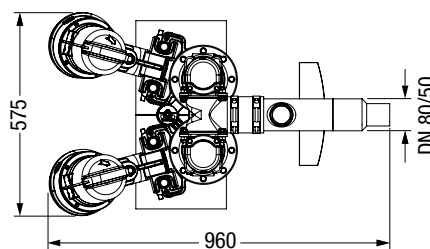
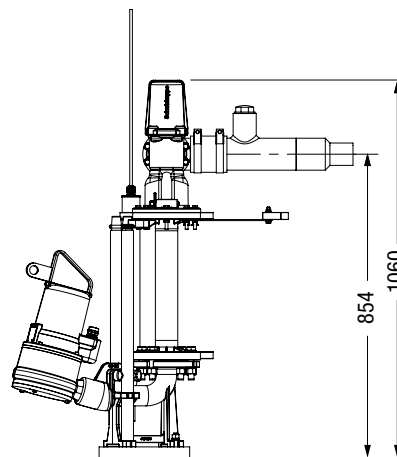

Duo version with two pumps

Pump	Art. no.
STZ 1300	STZ1300-D*
STZ 2500	STZ2500-D*
STZ 3700	STZ3700-D*
GTF 1400	GTF1400-D*
GTF 1600	GTF1600-D*
GTF 2600	GTF2600-D*
GTF 4000	GTF4000-D*
GTK 1300	GTK1300-D*
GTK 2600	GTK2600-D*
GTK 3700	GTK3700-D*

*Custom made product (delivery time on request)

Pumping capacity

