

Data sheet

Ecoguss project drain, press. fl. DN 70, vertical, Slotted cover

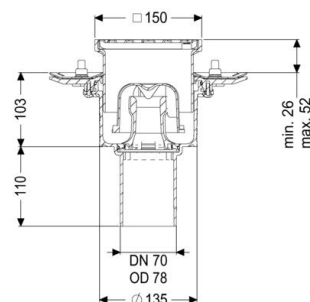

Article information

article number: 48878.11
 EAN code: 4026092032848
 Price group: 40

Product advantages

- Scientifically confirmed sound protection effect
- Highest fire protection standards

Description

The Ecoguss project drain is used for point drainage and is equipped with a pressure sealing flange as well as a removable odour trap, a lip seal and a temporary protective cover. The recyclable composite material Ecoguss meets the highest noise protection requirements, is temperature-resistant, resistant to aggressive media, and has a permanently corrosion-free surface. It is also briefly flammable from 100 to 400 degrees Celsius. The pressure sealing flange with bolts and screws made of stainless steel is used for the clamping or welding of bitumen and polymer bitumen sheets as well as for polymer and elastomer sealing sheets. Only the sealing sheets tested by the manufacturer may be used for watertight seals. The outlet socket is suitable for connection to SML cast iron pipes. Separate equipotential bonding is not necessary.

General features

Standard	EN 1253-1
Nominal size (DN)	70
Outer diameter (OD)	78 mm
Approval	Z-19.53-2414,Z-19.53-2414_V,Z-19.17-1719,Z-19.17-1719_V
Odour trap	included

Version

System	125
Waterproofing layer on the upper section	Connection flange
Waterproofing layer on the drain body	Press sealing flange (suitable for creating watertight seals)
Sealing water height	50 mm

Dimensions

Vertical adjustment	
Net weight	2.32 kg
Gross weight	2.95 kg
Diameter	273 mm
Type of height adjustability	vertically adjustable upper section
Length	273 mm
Width	273 mm
Packaging dimension: length	400 mm
Packaging dimension: width	300 mm
Packaging dimension: height	400 mm

Tank/drain body

Number of outlets	1
Material of drain body	Ecoguss resistant
Socket version	vertical

Coverage features

Type of cover	Slotted cover
Cover material	Stainless steel 14301
Colour of cover	silver
Width of cover	138 mm
Length of cover	138 mm
Surface	Polished SST
Frame material	ABS
Locking	screwed
Load class	K 3 (EN 1253-1)
Rim width	150 mm
Rim length	150 mm
Max. flooring height	25 mm
Upper section	vertically adjustable
Shape of upper section	square
Upper section material	ABS