

Data sheet

## Lifting station Aqualift M Tronic, GTF 500

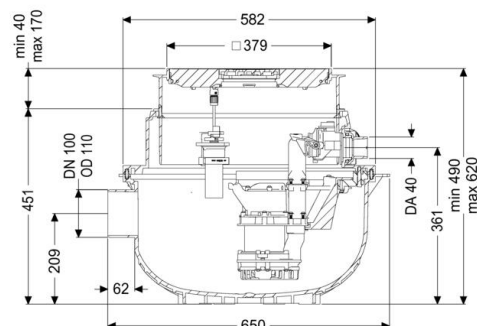

### Article information

article number: 280550S  
 EAN code: 4026092082645  
 Price group: 20

### Product advantages

- Space-saving due to installation in floor slab with integrated drainage function
- Easy retrofitting from Mono to Duo possible
- Quiet operation, as the pump installation does not cause any structure-borne sound emissions.

### Description

The ready to plug in lifting station for faecal-free wastewater is equipped with one or two submersible pumps and a backflow preventer. The collection tank made of permanently resistant polymer (PE) has an open pump tank. One-handed closures enable easy removal of the integrated components. The system for installation in the floor slab is preassembled for final installation on site.

### General features

Colour	black
Standard	EN 12050-2
Type of wastewater	without sewage
Installation situation	floor slab installation
Delivery state	Installation-ready (connection parts must be connected on site)
System type	Tronic

### Version

Type of system	Single unit
Pump control	Control unit
Backflow preventer	integrated

### Dimensions

Net weight	25.6 kg
Gross weight	27 kg
Groundwater resistant from lower edge of base section	3000 mm
Installation depth	490 620 mm
Type of height adjustability	vertically adjustable upper section
Length	617 mm
Width	585 mm
Packaging dimension: length	600 mm
Packaging dimension: width	600 mm
Packaging dimension: height	480 mm

### Tank/drain body

Pressure pipe connection (DN)	32
Pressure pipe connection (OD)	40 mm
Inlet nominal size (DN)	100
Pumping volume	20 l

### Coverage features

Type of cover	Cover plate with slotted cover
Cover material	Polymer
Colour of cover	black
Width of cover	366 mm
Length of cover	366 mm
Locking	Lock & Lift
Load class	K 3 (EN 1253-1)

### Pumping device

Pump	GTF 500
Number of pumps	1
Connection type	coded plug
Operating voltage	230 V
Protection class (pump)	IP 68 (3m)
Temperature monitoring	integrated
Max. temperature (permanent) of conveyed material	40 °C
Hot water resistance for a short time (2 min)	80 °C
Max. pumping capacity	10 m <sup>3</sup> /h
Max. pumping height	8 m
Speed	2800 U/min
Power P1	0.6 kW
Power P2	0.36 kW
Operating mode	S1
Type of pump connection cable	H07RN-F 3G 1.5 mm <sup>2</sup>
Impeller type	Multi-vane impeller
Free passage	10 mm
Length of mains cable for pump	5 m
Rated current	2,7  A

### Pumping capacity



### Control

Control unit	Comfort
Alarm sensor	optical probe
Level measurement instrument	Immersion pipe
Type of level measurement	pneumatic
Protection class control unit	IP 54
Mains frequency	50 Hz
Operating voltage	230 V
Connection type	coded plug
Length of mains cable for control unit	1.4 m
Potential-free contact	optional
GSM interface	yes
USB interface	yes
Log book function	yes
Multi-line display	yes
Battery buffering	yes
Self-diagnosis system (SDS)	yes
Type of fuse required (control unit)	C 16 A
Rated current	