

## Aqualift S Compact lift stat. Mono, GTF 500, Floor slab, tileable

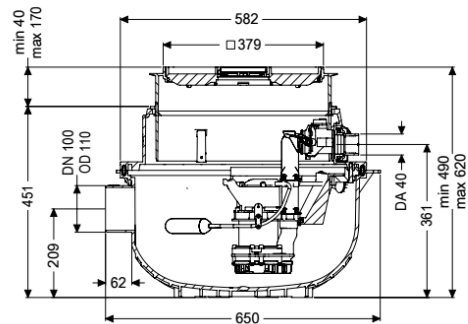

### Article information

Item no.: 280500X  
 GTIN: 4026092082577  
 Price group: 20

### Advantages

- Space-saving due to installation in floor slab with integrated drainage function
- Easy retrofitting from Mono to Duo possible
- Quiet operation, as the pump installation does not cause any structure-borne sound emissions.

### Description

The ready to plug in lifting station for faecal-free wastewater is equipped with one or two submersible pumps and a backflow preventer. The collection tank made of permanently resistant polymer (PE) has an open pump tank. One-handed closures enable easy removal of the integrated components. The system for installation in the floor slab is preassembled for final installation on site.

#### Variant

Type of system:	Single unit
Pump control:	Float switch
Backflow preventer:	integrated

#### General characteristics

Colour:	black
Standard:	EN 12050-2
Type of wastewater:	without sewage
Installation situation:	floor slab installation
Delivery state:	Installation-ready (connection parts must be connected on site)
System type:	Mono

#### Dimensions

Net weight:	22,5 kg
-------------	---------

Gross weight:	23,4 kg
Groundwater resistant from lower edge of base section:	3000 mm
Installation depth:	490 - 620 mm
Type of height adjustability:	vertically adjustable upper section
Length:	617 mm
Width:	585 mm
Packaging dimension:	length
Packaging dimension:	width
Packaging dimension:	height
Tank/drain body	
Pressure pipe connection (DN):	32
Pressure pipe connection (OD):	40 mm
Inlet nominal size (DN):	100 mm
Pumping volume:	16 l
Coverage features	
Type of cover:	tileable cover plate
Cover material:	Polymer
Colour of cover:	silver grey
Width of cover:	366 mm
Length of cover:	366 mm
Drainage function:	yes
Locking:	Lock & Lift
Load class:	K 3 (EN 1253-1)
Max. flooring height:	16 mm
Pumping device	
Pump:	GTF 500
Number of pumps:	1
Connection type:	Schuko (earthed contact) 2-pin
Rated current:	2,7 A
Length of mains cable for pump:	5 m
Protection class (pump):	IP 68 (3m)
Temperature monitoring:	integrated
Max. temperature (permanent) of conveyed material:	40 °C
Hot water resistance for a short time (2 min):	80 °C
Max. pumping capacity:	10 m <sup>3</sup> /h
Max. pumping height:	8 m
Speed:	2800 U/min
Power P1:	0,6 kW
Power P2:	0,36 kW
Operating mode:	S1
Type of fuse required (electrical protection):	C 16 A
Type of pump connection cable:	H07RN-F 3G 1.5 mm <sup>2</sup>
Impeller type:	Multi-vane impeller
Free passage:	10 mm

Control

Level measurement instrument:

Type of level measurement:

Mains frequency:

Operating voltage:

Connection type:

Rated current:

Float switch

mechanical

50 Hz

230 V

Schuko (earthed contact) 2-pin

2,7 A