

## Pumping station Aquapump XXL Tronic, GTK 5200-S1

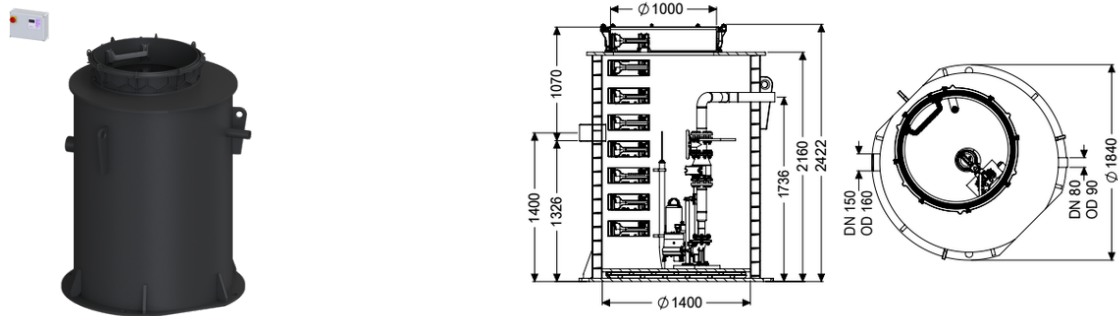

### Article information

Item no.: 8743045  
 GTIN: 4026092078136  
 Price group: 60

### Advantages

- Maximum safety
- Flexible installation
- Also handles large quantities of wastewater without sewage

### Description

The pumping station approval for wastewater with and without sewage is equipped with one or two submersible pumps, backflow preventer and shut-off valve for the pressure pipe. The collection tank made of permanently resistant polymer (PE) has an open pump tank (wet installation) with universal connection options. The KESSEL modular system provides different engineering chamber options as accessories for the further layout. Stainless steel pump removal chain available as accessory. Art. no. 680 528 = length 2 m 680 529 = length 3 m 680 530 = length 4 m 680 531 = length 5 m

#### Variant

Note on installation depth:	in combination with a chamber module
Type of system:	Single unit
Shut-off valve:	Shut-off valve made of cast iron
Passage seal for conduit pipe (DN):	100
Access steps:	yes
Passage seal for ventilation pipe (DN):	100
Installation:	Wet installation
Rim width:	Control unit
Backwater protection:	integrated
Pressure pipe connection:	horizontal
Sound absorption mat:	Twin walled re-enforced pipe chamber

#### General characteristics

Colour: black

Standard:	EN 12050-2 as well as EN 12050-1 (without ATEX requirements)
Type of wastewater:	for wastewater with and without sewage
Installation situation:	underground installation
Delivery state:	Pre-mounted for final assembly on site (pumps and sensor system must be fitted on site and control unit must be connected)
System type:	Tronic
Dimensions	
Net weight:	609,5 kg
Gross weight:	677,5 kg
Groundwater resistant from lower edge of base section:	3000 mm
Length:	1880 mm
Width:	1880 mm
Height:	2440 mm
Packaging dimension:	length
Packaging dimension:	width
Packaging dimension:	height
Tank/drain body	
Pressure pipe connection (DN):	80
Pressure pipe connection (OD):	90 mm
Distance from centre of outlet pipe to tank bottom:	1735 mm
Distance pipe bottom inlet to tank bottom:	1320 mm
Distance from centre of inlet pipe to tank bottom:	1400 mm
Distance from inlet pipe invert to top of tank:	1090 mm
Inlet nominal size (DN):	160 mm
Inlet nominal size (DN):	150 mm
Inlet type:	1
Clear width of tank (LW):	1600 mm
Clear width of entry (LW):	1000 mm
Pumping volume:	900 l
Pumping device	
Pump control:	GTK 5200
Number of pumps:	1
Weight:	56 kg
Connection type:	Direct connection
Rated current:	8,7 A
Length of mains cable for pump:	10 m
Self-diagnosis system (SDS):	I
Insulation class:	H
Cos phi - power factor:	0,85
Protection class control unit:	IP 68 (20m)
DSC:	integrated

Max. temperature (permanent) of conveyed material:	40 °C
Max. pumping capacity:	51,6 m <sup>3</sup> /h
Max. pumping height:	31,6 m
Speed:	2840 U/min
Power P1:	5,2 kW
Power P2:	4,4 kW
Operating mode:	S1
Type of pump connection cable:	H07RN8-F PLU 10G 1.5 mm <sup>2</sup>
Impeller type:	Single-vane impeller
Control	
Control unit:	Comfort Plus
Motor protection switch:	yes
Alarm sensor:	Level sensor
Level measurement instrument:	Level sensor
Type of level measurement:	hydrostatic
Protection class probe:	IP 54
Mains frequency:	50 Hz
Operating voltage:	400 V
Connection type:	Direct connection
Potential-free contact:	yes
GSM interface:	yes
USB interface:	yes
Log book function:	yes
Multi-line display:	yes
Battery buffering:	yes
Self-diagnosis system (SDS):	yes
Rated current:	8,7 A